

SHG

Butter Homogenizer

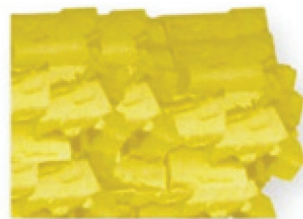

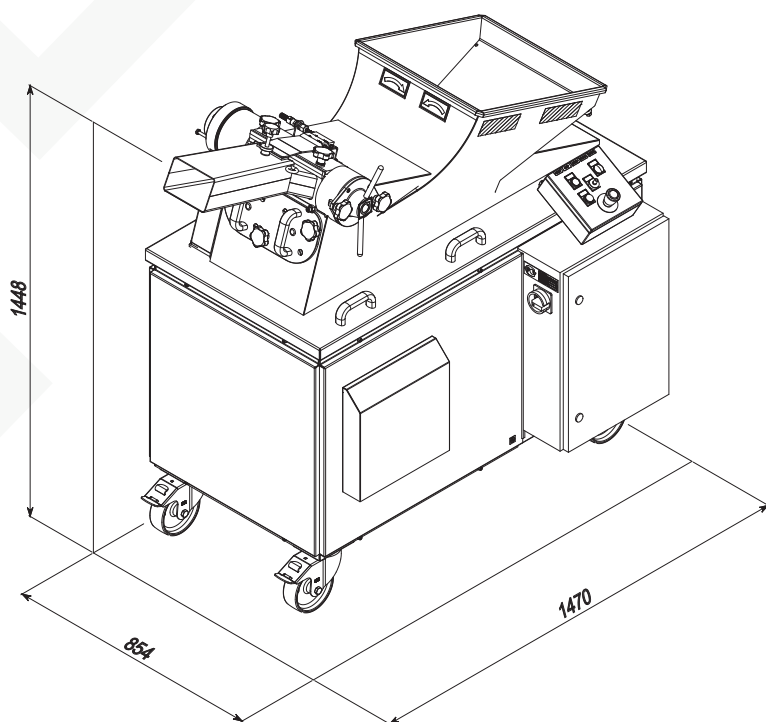

Butter homogenizer SHG is designed to rework bulk butter before re-packaging. Homogenizer SHG can be used with any butter filling and wrapping machine. Homogenizing is necessary to regain butter properties as they were before long storage or deep freezing. When butter is homogenized, it is ready again for packaging into customer size portions.

TECHNICAL DATA

Machine type	impeller type, continuous operation
Applicable product	butter
Max. capacity, kg/h	up to 1520
Product input temperature, °C	+6....+10
Product output temperature, °C	+12....+14
Feeding	60 kg horizontal hopper with 2 augers
Control	relay logic and control panel with buttons and switches
Productivity	regulation incrementally
Washing mode	manual
Number of impeller blades	12
Auger speed, rpm	12-22
Rated power input, kVA	11
Voltage, V	230 / 400 ± 10%
Frequency, Hz	50/60
Electricity supply	3 phase
Approx. machine size (L x W x H), mm	1470 x 902 x 1410
Approx. machine weight, kg	600