

RFS120

Rotary Filling and Sealing Machine

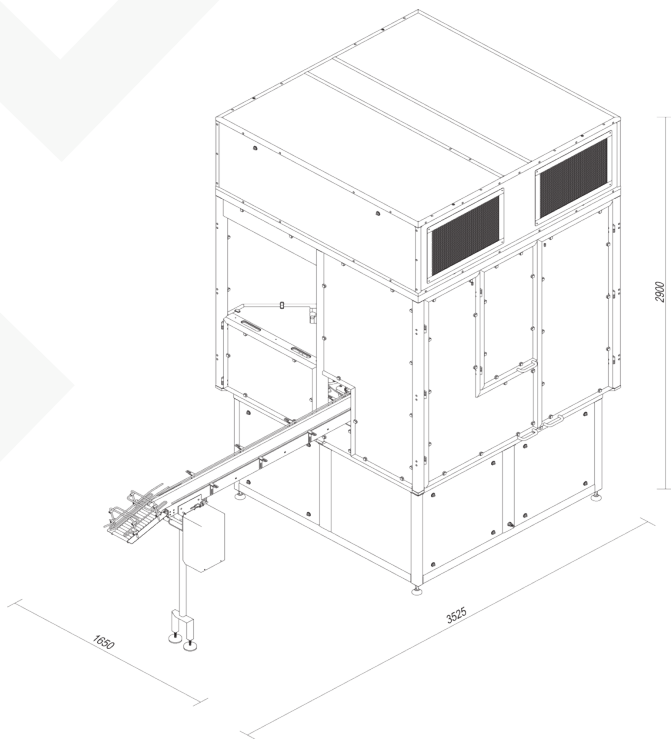



Cup filling and sealing machine RFS120 is designed for yogurt, sour cream, kefir to be filled into pre-made containers with aluminum foil and/or lids. Rotary type machine has 3 rows.

RFS120 main features

- Cup filling and sealing machine for filling the liquid products and paste-type products.
- Shapes of cups: round or square.
- Easy to shift between portion weight by changing the height.
- Stainless steel dosing unit.
- Rotary table and machine body covers from stainless steel.
- Machine safety covers in accordance with CE safety requirements.
- HEPA filter chamber.
- Sensor for cup detection.
- UV lamp.
- Round grouping table at the end of conveyor (optional).

TECHNICAL DATA

Machine type	rotary type, cycle operation, three lines
Applicable products	yogurt, Greek yogurt, sour cream, kefir
Max. capacity, portions/min	up to 105 for 100 – 250 g up to 60 for 300 – 500 g
Product input temperature, °C	+13....+15
Feeding	direct product feeding by pump
Dosing type	volumetric
Packaging materials	pre-formed plastic cups with heat sealable aluminum foil lids, PP, PS lids
Closing type	heat-sealing pre-cut foil and lid covering
Control	PLC and HMI with Touch Screen
Accuracy, %	1
Productivity regulation	incrementally duellement
Washing mode	CIP
Compressed air pressure, MPa (bar)	0,6 – 0,8 (6 – 8)
Compressed air consumption, m ³ /min	0,75
Rated input power, kVA	36
Voltage, V	230/400 +-10% AC
Frequency, Hz	50/60
Electricity supply	3 phase
Approx. machine size (L x W x H), mm	35250 x 1650 x 2900
Approx. machine weight, kg	1700