

PM

Flow-Pack Machine

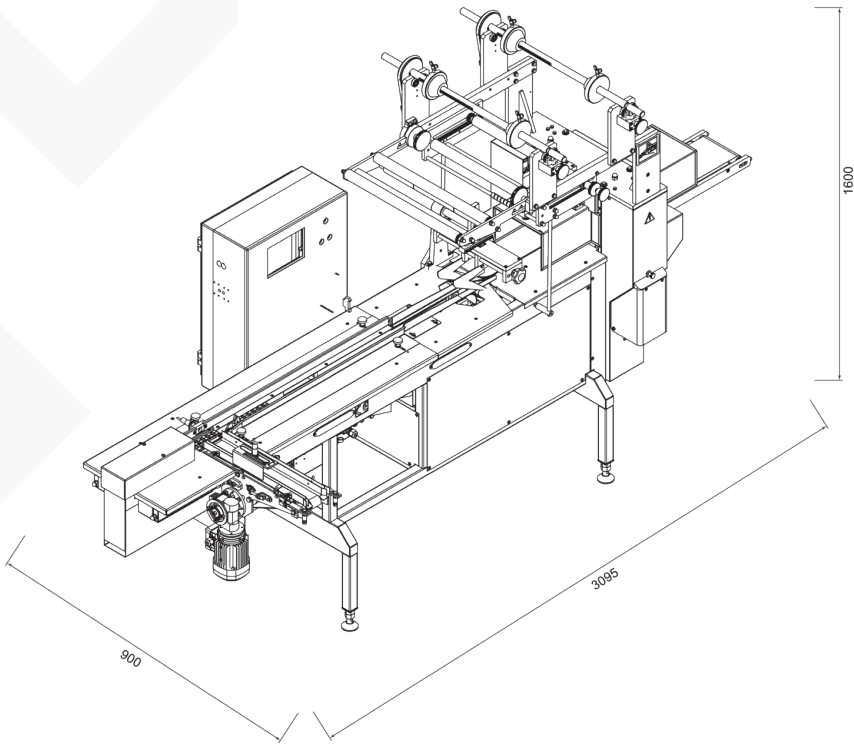



PM is a horizontal Flow-Pack type machine. Packs are sealed on three sides from a roll of heatsealable packaging film. It is compatible with AR2T curd filling and wrapping machine.

TECHNICAL DATA

Machine type	Flow - Pack
Product to pack	curd (tvorog) or other food products
Max. capacity, packs/min	up to 85 *depends on the product size
Sizes of package, mm	length min 50 – max 240 width min 55 – max 210 height min 10 – max 80
Wrapping material	laminated, bonded or micro-perforated polypropylene, polyethylene, heat-shrinkable and trimmable materials
Inner reel (core) diameter, mm	75
Outer reel diameter, mm	up to 450
Material thickness, mm	0,04
Control PLC and HMI with Touch Screen	PLC and HMI with Touch Screen
Productivity regulation	incrementally
Washing mode	manual
Compressed air supply, MPa (bar)	0,58-0,63 (5,8-6,3)
Compressed air consumption, m ³ /min	up to 0,005
Rated power input, kVA	5,15
Voltage, V	230/400 ±10%
Frequency, Hz	50/60
Electricity supply	3 phase
Approx. machine size (L x W x H), mm	3095 x 900 x 1600
Approx. machine weight, kg	370