

# BH

## Butter Homogenizer

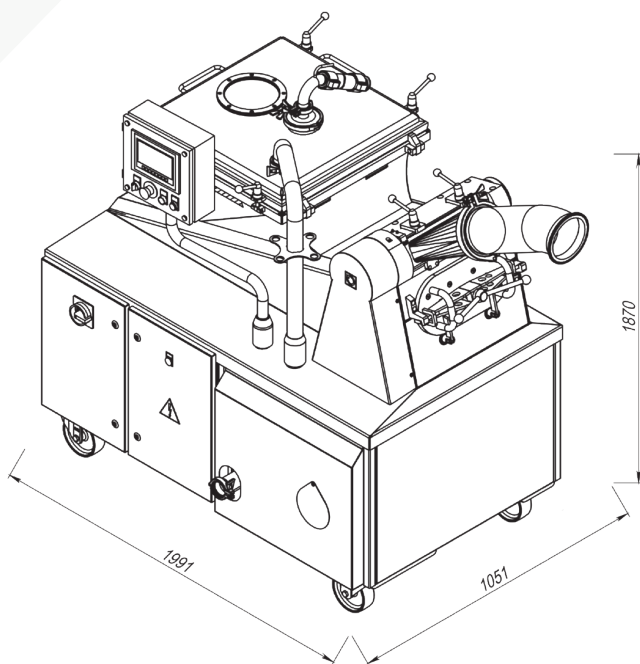



BH homogenizer is designed to homogenize bulk butter before repacking. This function is necessary to regain butter properties as they have been before freezing. When butter is homogenized, it is ready again for packaging into customer size portions. Homogenizer BH can be used with any butter filling and wrapping machine.

Robust design which allows to rework cooled/chilled butter (blocks), easy maintenance, CIP system are exclusive features of FASA new homogenizer.

## TECHNICAL DATA

Machine type	impeller type, continuous operation
Applicable product	butter
Max. capacity, kg/h	up to 2000 *depends on input temperature and butter block size
Product input temperature, °C	0...+10
Product output temperature, °C	+10....+14
Feeding	120 kg hopper with 2 augers
Auger drive power, kW	2 x 0,75
Impeller drive power, kW	15
Impeller speed, rpm	400-1000
Number of impeller blades	8
Control	PLC and HMI with Touch Screen
Productivity regulation	incrementally
Washing mode	CIP
System pressure, MPa (bar)	up to 0,2 (2)
Compressed air supply, MPa (bar)	0,4-0,8 (4-8)
Compressed air consumption, m <sup>3</sup> /min	minimal, require only in CIP mode
Rated power input, kVA	30
Voltage, V	230/400 ±10%
Frequency, Hz	50/60
Electricity supply	3 phase
Approx. machine size (LxWxH), mm	1991 x 1051 x 1870
Approx. machine weight, kg	740