

ARM

Butter / Margarine Filling and Wrapping Machine

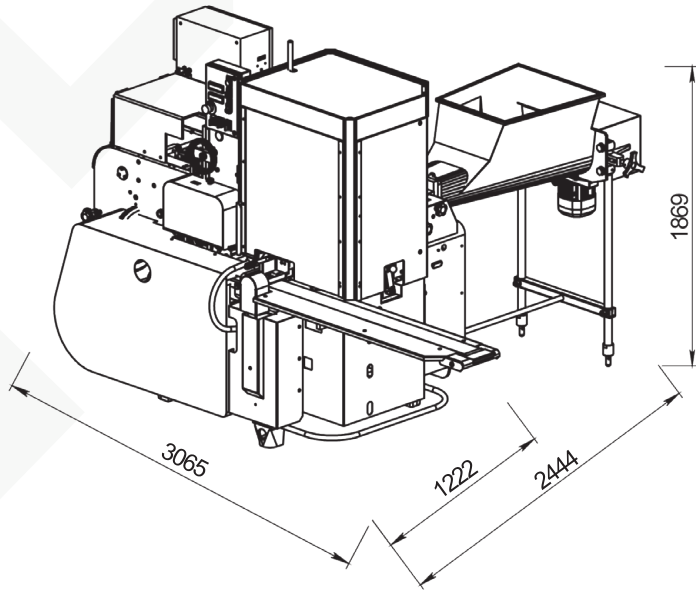



ARM main features

- Packing butter or margarine into consumer size portions.
- Possibility to shift between portion weight by changing the height of brick.
- Shapes of bricks: rectangular.
- Pneumatic or mechanical compensator.
- Stainless steel dosing unit.
- Stainless steel rotary table with synthetic inserts.
- Machine body covers from stainless steel.
- Machine safety covers.
- Sensor for foil tracking.
- Foil centering device with photocell.
- UV lamp.
- Central lubrication system (optional).
- Possible printer (optional): Ink jet.

Butter wrapping machine ARM is designed to fill and wrap butter or margarine into aluminum foil.

TECHNICAL DATA

Machine type	rotary type, continuous operation
Applicable products	butter, margarine
Max. capacity, packs/min	up to 80
Dose mass, g	9 – 25
Product input temperature, °C	butter +10...+14; margarine +8...+14
Feeding	hopper with 2 horizontal augers
Dosing type	volumetric
Packaging material	laminated aluminum foil
Folding type of package	bottom folding
Inner reel (core) diameter, mm	70 or 75
Outer reel diameter, mm	up to 400
Material thickness, mm	0,05-0,08
Control	PLC and HMI with Touch Screen
Accuracy, g	9-15 g – 1 g; 20-25 g – 1,5 g
Productivity regulation	incrementally
Lubrication system	central (optional)
Washing mode	manual
Compressed air supply, MPa (bar)	0,4...0,6 (4...6)
Compressed air consumption, m ³ /min	0,013
Rated power input, kVA	9
Voltage, V	230/400 ± 10%
Frequency, Hz	50/60
Electricity supply	3 phase
Approx. machine size (LxWxH), mm	3065 x 2444 x 1869
Approx. machine weight, kg	1800