

ARM-B2

Butter / Margarine Filling
and Wrapping Machine

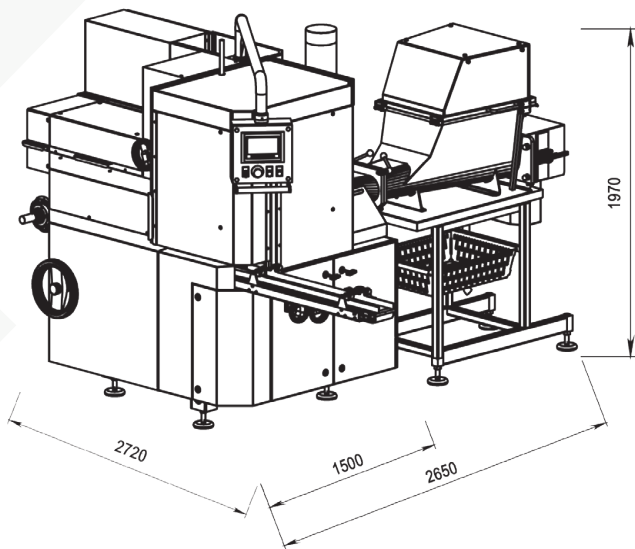



ARM-B2 main features

- Packing paste type products into consumer size portions.
- Easy to shift between portion weight by changing the height of brick, height adjustable by handle, the adjustment points are marked with a ruler.
- Shapes of bricks: rectangular, stick or semi-round.
- Pneumatic compensator.
- Stainless steel dosing unit.
- Pneumatic rotor switch.
- Stainless steel table with synthetic inserts.
- Machine body covers from stainless steel.
- Machine safety covers.
- Fully automatic lubrication system.
- Two sensors for foil tracking (roll width control; end of the roll).
- Foil centering device with photocell.
- Belt driven foil broaching shaft instead of chain.
- Stationary foil roll spindle.
- UV lamp.
- Possible printers (optional): Ink jet or Thermo-printer.

ARM-B2 is designed to fill and wrap butter and margarine in aluminum foil, parchment paper or ecoline. Machine can dose 100 – 250 g, capacity up to 70 packs/min.

TECHNICAL DATA

Machine type	rotary type, continuous operation
Applicable products	butter, margarine, spreads, edible fats, curd
Max. capacity, packs/min	up to 70
Dose mass, g	100-250
Product input temperature, °C	butter +10...+14; margarine +8...+14
Feeding	hopper with 2 horizontal augers or direct feeding
Dosing type	volumetric
Packaging material	laminated aluminum foil, parchment paper, ecoline *with memory
Folding type of package	bottom folding
Inner reel (core) diameter, mm	70 or 75
Outer reel diameter, mm	up to 400
Material thickness, mm	0,05-0,08
Control	PLC and HMI with Touch Screen
Accuracy, %	1
Productivity regulation	incrementally
Lubrication system	automatic
Washing mode	manual or CIP *except dosing unit (optional)
Compressed air supply, MPa (bar)	0,4...0,6 (4...6)
Compressed air consumption, m ³ /min	0,013
Rated power input, kVA	9 *with hopper, 4,5 *direct feeding
Voltage, V	230/400 ± 10%
Frequency, Hz	50/60
Electricity supply	3 phase
Approx. machine size (LxWxH), mm	2720 x 2650 x 1970 *with hopper 2720 x 1500 x 1970 *without hopper
Approx. machine weight, kg	1800 *with hopper 1650 *without hopper