

# ARM-B3

Butter / Margarine Filling  
and Wrapping Machine

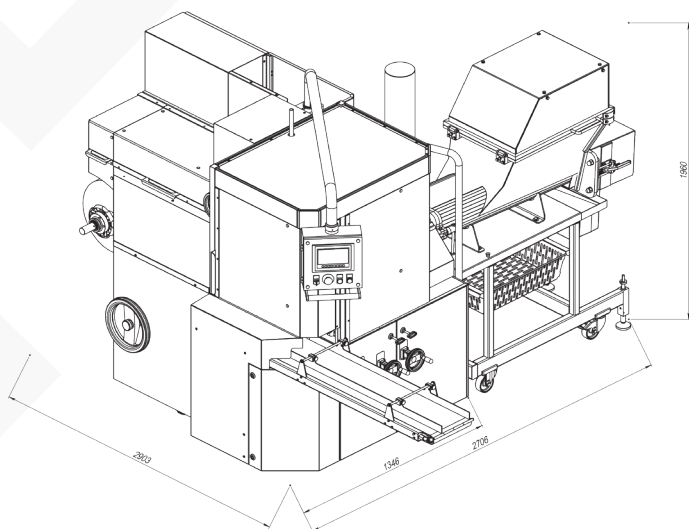



### ARM-B3 main features

- Packing paste type products into consumer size portions.
- Easy to shift between portion weight by changing the height of brick, height adjustable by handle, the adjustment points are marked with a ruler.
- Shapes of bricks: rectangular or semi-round.
- Pneumatic compensator.
- Stainless steel dosing unit.
- Pneumatic rotor switch.
- Stainless steel table with synthetic inserts.
- Machine body covers from stainless steel.
- Machine safety covers.
- Automatic lubrication system.
- Two sensors for foil tracking (roll width control; end of the roll).
- Foil centering device with photocell.
- Belt driven foil broaching shaft instead of chain.
- Stationary foil roll spindle.
- UV lamp.
- Possible printers (optional): Ink jet, Thermo-printer or Cold emboss coding unit.

ARM-B3 is designed to fill and wrap butter and margarine in aluminum foil, parchment paper or ecoline. Machine can dose 200 – 500 g, capacity up to 40 packs/min.

## TECHNICAL DATA

Machine type	rotary type, continuous operation
Applicable products	butter, margarine, spreads, edible fats, curd
Max. capacity, packs/min	up to 40
Dose mass, g	200 – 500
Product input temperature, °C	butter +10...+14; margarine +8...+14
Feeding	hopper with 2 horizontal augers or direct feeding
Dosing type	volumetric
Packaging material	laminated aluminum foil, parchment paper, ecoline <small>*with memory</small>
Folding type of package	bottom folding
Inner reel (core) diameter, mm	70 or 75
Outer reel diameter, mm	up to 400
Material thickness, mm	0,05-0,08
Control	PLC and HMI with Touch Screen
Accuracy, %	1
Productivity regulation	incrementally
Lubrication system	automatic
Washing mode	manual or CIP <small>*except dosing unit (optional)</small>
Compressed air supply, MPa (bar)	0,4...0,6 (4...6)
Compressed air consumption, m <sup>3</sup> /min	0,013
Rated power input, kVA	9 <small>*with hopper</small> ; 4,5 <small>*direct feeding</small>
Voltage, V	230/400 ± 10%
Frequency, Hz	50/60
Electricity supply	3 phase
Approx. machine size (LxWxH), mm	2903 x 2706 x 1960 <small>*with hopper</small> 2903 x 1346 x 1960 <small>*without hopper</small>
Approx. machine weight, kg	1800 <small>*with hopper</small> 1650 <small>*without hopper</small>