

# AR6U

## Processed Cheese Filling, Wrapping and Cartoning Machine

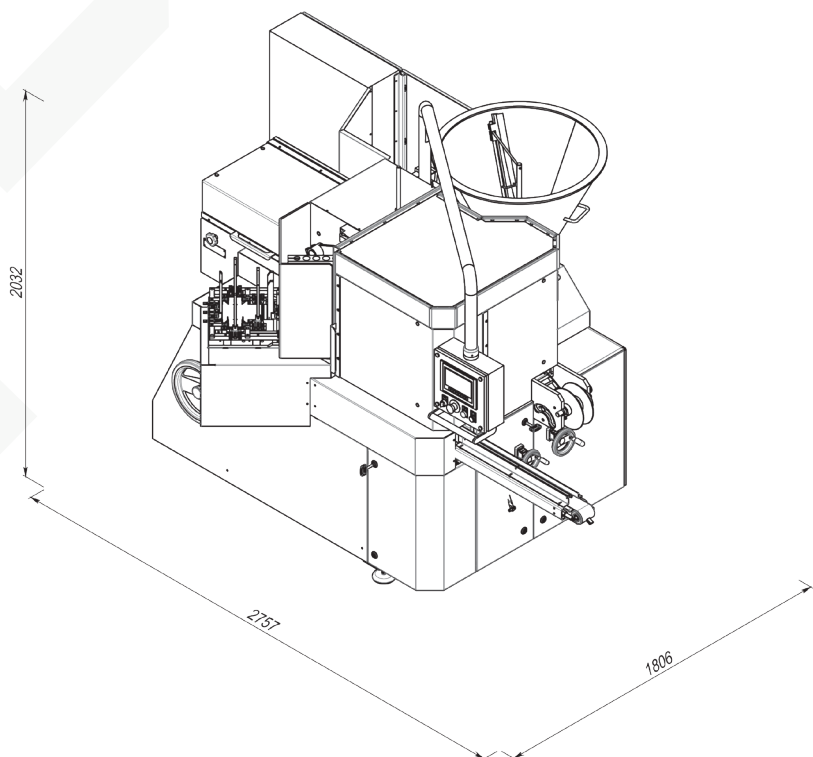



AR6U automatic packaging machine for foiling and heat-sealing of processed cheese with aluminum foil and packing into individual carton.

#### AR6U main features

- Shapes of package – rectangular.
- Packaging materials: coated aluminum foil and pre-cut cardboard blank.
- Heat-sealed package from coated aluminum foil.
- Foil cuts collecting system.
- Hot glue system “Robotech”.
- Machine safety covers.

## TECHNICAL DATA

Machine type	rotary type, continuous operation
Applicable products	processed cheese, cream cheese
Max. capacity, packs/min	up to 30
Dose mass, g	180 - 225 (one size)
Viscosity, CSt	3 000 - 10 000
Product density, g/cm	3 1,05 *otherwise specified by customer
Pack size	110 x 56 x 28 (180g); 110 x 56 x 31 (200g)
Product input temperature, °C	+65....+75
Feeding	double jacket (heating) 85l hopper with agitator
Dosing type	volumetric
Packaging materials	coated aluminum foil and pre-cut cardboard blank
Inner reel (core) diameter, mm	70 or 75
Outer reel diameter, mm	up to 200
Material thickness (of foil), mm	0,012 – 0,014
Control	PLC and HMI with Touch Screen
Accuracy, %	2
Productivity regulation	incrementally
Washing mode	manual
Compressed air supply, MPa (bar)	0,6 (6)
Compressed air consumption, m <sup>3</sup> /min	0,23
Rated input power, kVA	14,16
Voltage, V	230/400 ±10%
Frequency, Hz	50/60
Electricity supply	3 phase
Approx. machine size (L x W x H), mm	2757 x 1806 x 2032
Approx. machine weight, kg	1900